

**RELAY
ASSOCIATES**

15 Colwell Lane
P.O. Box 625
Conshohocken, PA 19428
Tel. 610-941-2900
Fax. 610-941-3910
RelayAssoc@aol.com

**Type LJ High Speed
Auxiliary Relays**

**CATALOG / INSTRUCTION MANUAL
CI9605TAS**

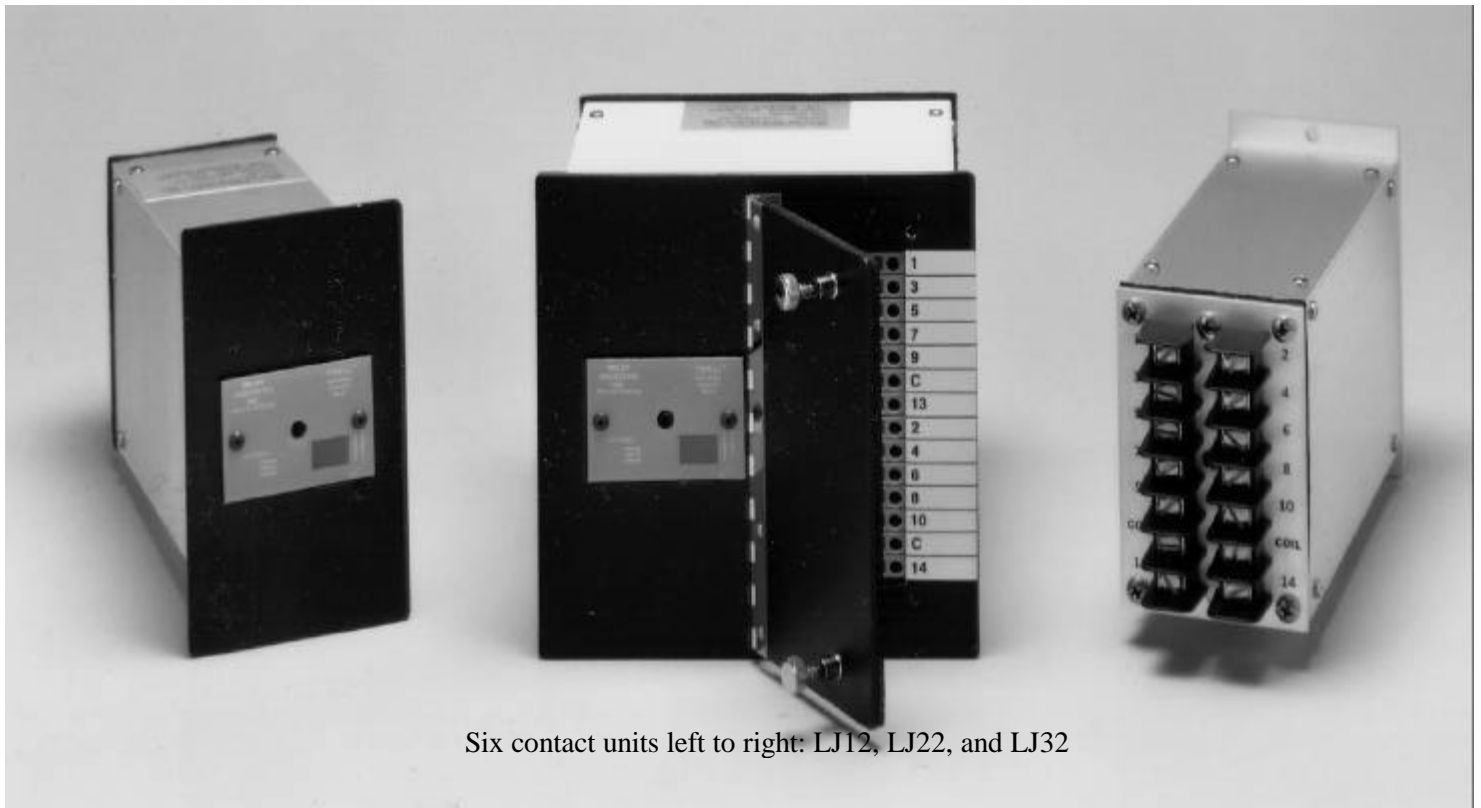

Six contact units left to right: LJ12, LJ22, and LJ32

TABLE OF CONTENTS

GENERAL DESCRIPTION	2
LJ RELAY MODEL DEFINITION CHART	3
APPLICATION	4
SPECIFICATIONS AND RATINGS	4
CONTACT RATING FOR LJ RELAYS PER ANSI C37.90	4
OPERATING DATA FOR CONTINUOUSLY RATED LJ RELAY PER ANSI C37.90	4
RECEIVING	5
ADJUSTMENTS.....	5
INSTALLATION.....	5
TESTING PROCEDURES.....	5
ELECTRICAL OPERATION-.....	5
MANUAL OPERATION -	5
TEST SWITCHES-.....	6
TARGET	6
OPERATION -	6
RESET:.....	6
ELECTRICAL SEAL-IN FEATURE.....	6
LOCAL RESET:	6
REMOTE RESET:.....	6
CONVERTING CONTACTS.....	6
PROJECTION MOUNT UNITS:	7
FLUSH MOUNT CASE:	7
LOWER DECKS: REMOVAL AND CONVERSION OF CONTACTS.....	8
TYPICAL TERMINAL BLOCKS	9
PANEL CUTOUT AND DRILLING FOR SEMI-FLUSH CASES.....	11
PROJECTION UNIT MOUNTING FOOTPRINTS.....	11

LIST OF TABLES

TABLE 1. MODEL IDENTIFICATION / ORDERING INFORMATION	3
TABLE 2. CONTACT RATINGS.....	4
TABLE 3. RELAY SPECIFICATIONS	4
TABLE 4. CUTOUT DIMENSIONS (INCHES).....	11

LIST OF FIGURES

FIGURE 1. INTERNAL SIDE AND FRONT VIEW OF A 6 CONTACT RELAY ASSEMBLY	7
FIGURE 2. CONTACT CARTRIDGE	8
FIGURE 3. CUTAWAY OF TOP RELAY DECK	9
FIGURE 4. TERMINAL BLOCKS.....	9
FIGURE 5. STANDARD WIRING DIAGRAM (EXCLUDING LJ4X SERIES)	10
FIGURE 6. ELECTRICAL SEAL IN WIRING SCHEMATIC	10
FIGURE 7. PANEL CUTOUT.....	11
FIGURE 8. PROJECTION MOUNT DRILLING DIMENSIONS.....	11
FIGURE 9. SCHEMATIC OF LJ41, LJ42, AND LJ43.....	12

General Description

The LJ relay is a high speed, high inertia auxiliary relay designed to operate in 4 milliseconds*. The relay can be configured with any combination of its two (2), six (6) or ten (10) contacts normally open or normally closed. The dustproof, all aluminum case is available in both flush or projection mount configurations. The patented shielded coil minimizes internally generated transients and provides immunity to misoperation from system transients.

The different models can be identified by referring to the table below.

* Refer to Table 2, page 3 for complete specifications.

LJ Relay Model Definition Chart

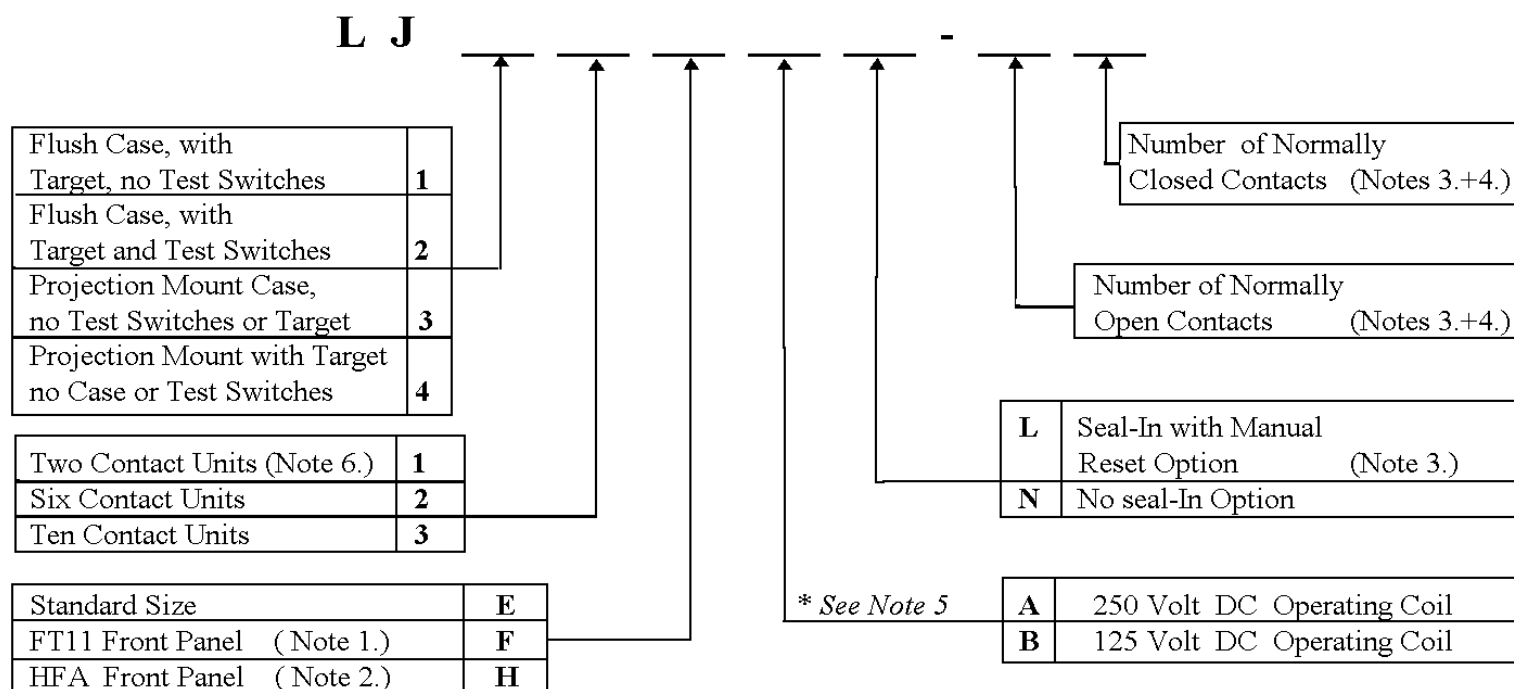

Note 1. Fits FT11 cutout (not available with the LJ23).

Note 2. Fits HFA Flush mount non-drawout cutout (not available with the LJ23).

Note 3. Selecting the seal-in unit reduces usable contacts by one. Not available on projection mount units.

Note 4. Summation of N/O and N/C contacts cannot exceed 2 for **LJ X 1** models, 6 for **LJ X 2** models, and 10 for **LJ X 3** models.

Note 5. 48 Volt Operating Coil is available by special order. Consult factory.

Note 6. 2 Contact Units only Available on **LJ4X** models.

Table 1. Model Identification / Ordering Information

Application

The LJ family of products is designed to be used where reliable high speed tripping is required. For lockout applications, the LJ is also available with an electrical seal-in feature (see Figure 6, page 10).

Specifications and Ratings

In tests conducted by an independent lab, the LJ relay was found to meet or exceed the Fast Transients and Surge Withstand requirements as defined by ANSI C37.90. Tables 2 and 3 below are in compliance with ANSI C37.90 rating specifications.

The **capacitive energy** required to induce a momentary contact closure is greater than 0.60 Joules.

Contact Rating for LJ Relays Per ANSI C37.90

Contact Circuit	Interrupting Rating		Make and Carry Contact Ratings	
	Resistive	Inductive (L/R=0.1)	Short Time(1 sec)	Continuous
125 VDC	1.1 amps	0.55 amps	30 amps	5 amps
250 VDC	0.55 amps	0.28 amps	30 amps	5 amps
125 VAC	5.76 amps	2.88 amps	60 amps	10 amps
250 VAC	2.88 amps	1.44 amps	60 amps	10 amps

Table 2. Contact Ratings

Operating Data for Continuously Rated LJ Relay Per ANSI C37.90

Coil Circuit Voltage (DC)	Operating Coil Resistance (Ohm)	Holding Coil Resistance (Ohm)	Typical Operate Time (ms) N.O. Contact		Operating Voltage (DC)	
			Pickup	Dropout (Typical)	Must Pickup	Must Dropout
125 (2&6 Contacts)	13	1490	4.5 (+/- 0.5)	15	100	15
125 (10 Contacts)	13	1490	5.0 (+/- 0.5)	15	100	15
250 (2&6 Contacts)	53	8700	4.5 (+/- 0.5)	15	200	30
250 (10 Contacts)	53	8700	5.0 (+/- 0.5)	15	200	30

Table 3. Relay Specifications

Receiving

Upon receipt of the relay, inspect the relay to verify that its model number agrees with the requisition. Also check for damage which may have been sustained in transit. If damage is evident, file a claim with the transportation company and notify your manufacturer's representative or Relay Associates directly at 610-941-2900.

If the unit is to be stored, Relay Associates recommend keeping the relay in its original packaging so as to protect the unit. When handling the relay, exercise reasonable care as to avoid severe impacts.

Adjustments

The relay has been designed and built with no adjustments to provide the user reliability and ease of use.

Installation

The relay is shipped from the factory pre-configured to the customer's specifications and should not require any changes on site. Mount the relays on switchboard panels or their equivalent (relays must be mounted on a vertical surface for proper target operation). Panel cutouts should be made for each relay to the dimensions found in the proper cutout drawings (page 11). Refer to Table 1, page 3 should there be a question as to what type relay you have. Panel fasteners are included in the shipping carton. Recommended wiring connections are as indicated by the appropriate drawing (Figures 5 and 6, page 10; Figure 4, page 9; and Figure 9 page 12).

Testing Procedures

Electrical Operation-

The relay can be tested by applying a rated voltage source which is capable of providing the necessary amperage momentarily. This will operate the relay electrically and change the state of all contacts. (**note:** During electrical operation, the relay will hold its contacts in the operated position until the electrical source has been removed from the coil.)

Manual Operation -

For testing purposes, the relay can also be operated manually by inserting a small probe (e.g. #2 Phillips screwdriver) through the center hole of the nameplate (M on Figure 1, page 7). Pushing in on this probe will move the armature, and thereby operate the contacts and target assembly (**note:** Not applicable on LJ32 or LJ33)

Test Switches-

As an option, test switches are provided on both sides of each contact and the operating coil (refer to Figure 5, page 10). The test switches are used to isolate each individual contact or the operate coil for testing purposes. Small banana plug electrical connectors (3/64" dia.) can be used to electrically connect to the relay circuit at the test switches. In order to assure connection to the proper circuit, please refer to Figure 5, page 10. Opening the appropriate test switches will allow the user to operate the relay while isolating it from the external circuits.

Important: *When completed, be sure to close all test switches and secure the test switch cover plate.*

Target

Operation -

A direct driven, manually resettable target is standard on flush mount units. When the relay operates, a bright orange target and a small black reset tab are exposed.

Reset:

After de-energizing the relay, pushing up the black tab will reset the target. Target reset can only be accomplished manually.

Electrical Seal-In Feature

An LJ relay with this option will maintain its operated position indefinitely using a rated voltage source until reset by one of the methods below. The recommended wiring for this option is shown in Figure 6, page 10. Due to internal space requirements, an LJ12 which is ordered with this option will be supplied in a LJ13 case. (**note: reduces number of usable contacts by one**)

Local Reset:

When reset is desired, depress the small push-button located on the front panel of the relay. This will break the holding current allowing the relay to reset.

Remote Reset:

Remote reset of the coil can also be accomplished by connecting a controllable contact, such as a SCADA contact, in series with the electrical seal-in(see Figure 6, page 10).

Converting Contacts

These instructions assist the user in converting any or all of the contacts located in the upper deck of the relay. Be sure to read each instruction fully before beginning the work outlined in that step.

Projection mount units:

1) If you have an LJ32 or LJ33, proceed to step 4 under **Flush mount case** below. If you have an LJ41, LJ42 or LJ43, follow the **Flush mount case** instructions below, skipping step 4.

Flush mount case:

- 1) Using a 1/16" Allen wrench, remove and retain the two button head (4-40 X 1/4") nameplate retaining screws.(labeled N in Figure 1)
- 2) Remove and retain the nameplate.
- 3) Observing the assembly order, remove and set aside the target reset and target.
- 4) Remove the four(4) screws located at the corners of the case. These are on the terminal strip end of the case. Remove the relay from the case (**note:** On units with the seal-in option, you must first unscrew the collar from around the reset button)
- 5) Noting the orientation of the cover, use a 1/4" standard screwdriver to remove the two(2) screws(labeled C in Figure 1) which hold the cover in place. Remove cover.

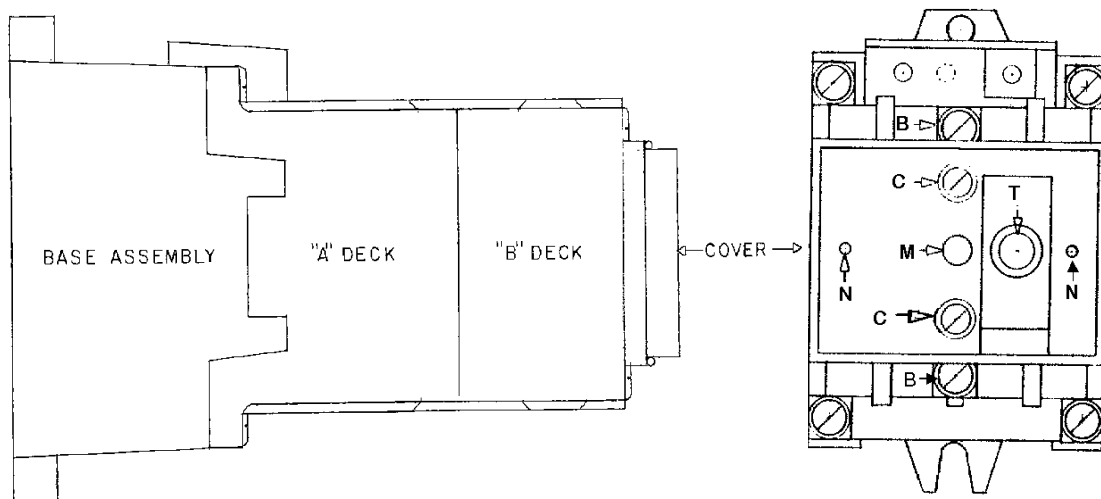

FIGURE 1. INTERNAL SIDE AND FRONT VIEW OF A 6 CONTACT RELAY ASSEMBLY

6) Noting the location of the target magnet (T in Figure 1, page 7.), use a 1/4" screwdriver to back out the red cross bar screw (Figure 3, page 9) about one inch. Now rotate the red cross bar 90 degrees to provide access to the selected contact.

7) Locate the contact you wish to convert and remove the terminated leads from the terminals of the selected contact (refer to Figure 2). (**note:** On units with the electrical seal-in, you must first remove screw B (Figure 1, page 7) which holds the reset button in place. Move this assembly out of the way.)

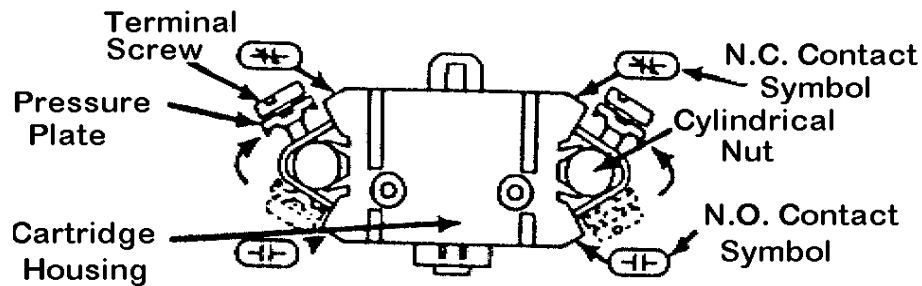

FIGURE 2. CONTACT CARTRIDGE

8) Lift the contact cartridge out of its location. Turn the cartridge over and rotate the two cylindrical nuts (refer to Figure 2) to the required position (inserting the terminal screws a turn or two helps to facilitate this) in order to reassemble. Insert the cartridge back into its position. Verify the desired contact form by noting the N.C. or N.O. symbol on the contact. The symbol that is visible (facing upward) is the selected configuration.

9) Reassemble the relay in the exact reverse order stated above. Using a screwdriver, hand tighten all screws securely. When assembly is complete no further adjustments are necessary, however testing the relay is recommended to assure its proper operation.

Lower Decks: Removal and conversion of contacts

Should the user wish to convert any of the contacts in the remaining decks(A and/or B), follow the direction below:

- 1) Follow steps one through six (6) above for the type of mounting configuration you have.
- 2) Back out the screw in the center of the red operator completely (Figure 3, page 9)and set both screw and red operator aside.
- 3) Carefully remove the eight (8) terminated leads from the four (4) contacts in the uppermost deck (**note:** be sure to write down which sets of leads go to which contact).
- 4) Remove the two (2) deck mounting screws in Figure 3, page 9. These screws are long and hold the different decks together.
- 5) The deck is now ready to be removed. As you remove the deck note its orientation, the bottom of each deck is keyed to assist in assembly. As you lift the deck, the black cross bar (Figure 3.) for that deck will fall out of its center.

Set the deck with its corresponding black crossbar aside.

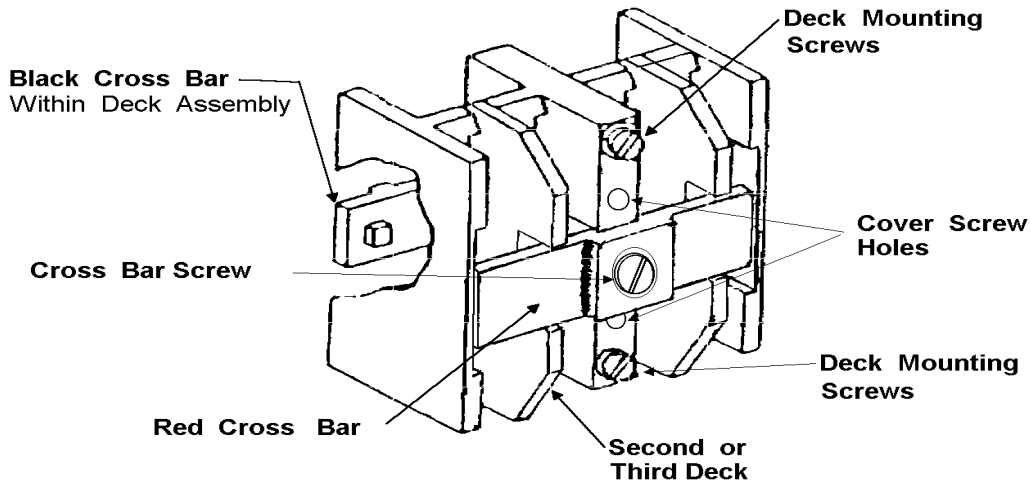
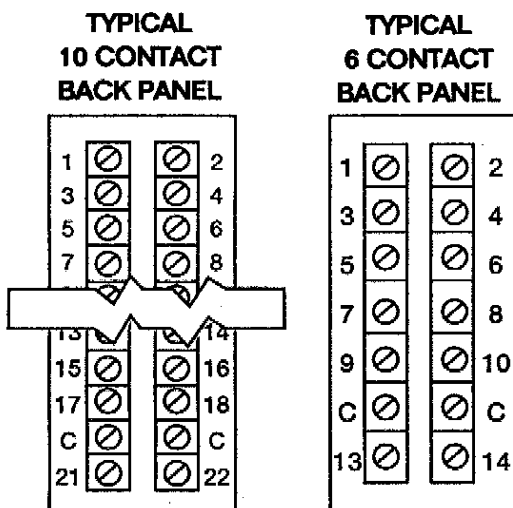

FIGURE 3. CUTAWAY OF TOP RELAY DECK

- 6) You may now convert the contacts as listed in steps 7-9 of **converting contacts**.
- 7) Reassemble in the reverse order listed above. Take particular care when rewiring the relay to insure that all pairs of leads match up and go to the properly configured contact. If there is any question as to the proper wiring pattern, refer to Figure 5, page 10. **[note:** All decks are labeled near the contact wells as Axx, Bxx, or Cxx. When assembling make sure you assemble A first, then B, then, if it is a 10 contact relay, C deck. (refer to Figure 1, page 7)]

Typical Terminal Blocks



- Contacts are between 1 and 2, 3 and 4, etc.
- Highest numbered terminals are wired to normally open contacts.
- Contacts 21-22 / 13-14 are not available for use on an electrical seal-in unit.
- Coil is wired between terminals labeled "C" and is not polarity sensitive.

FIGURE 4. TERMINAL BLOCKS

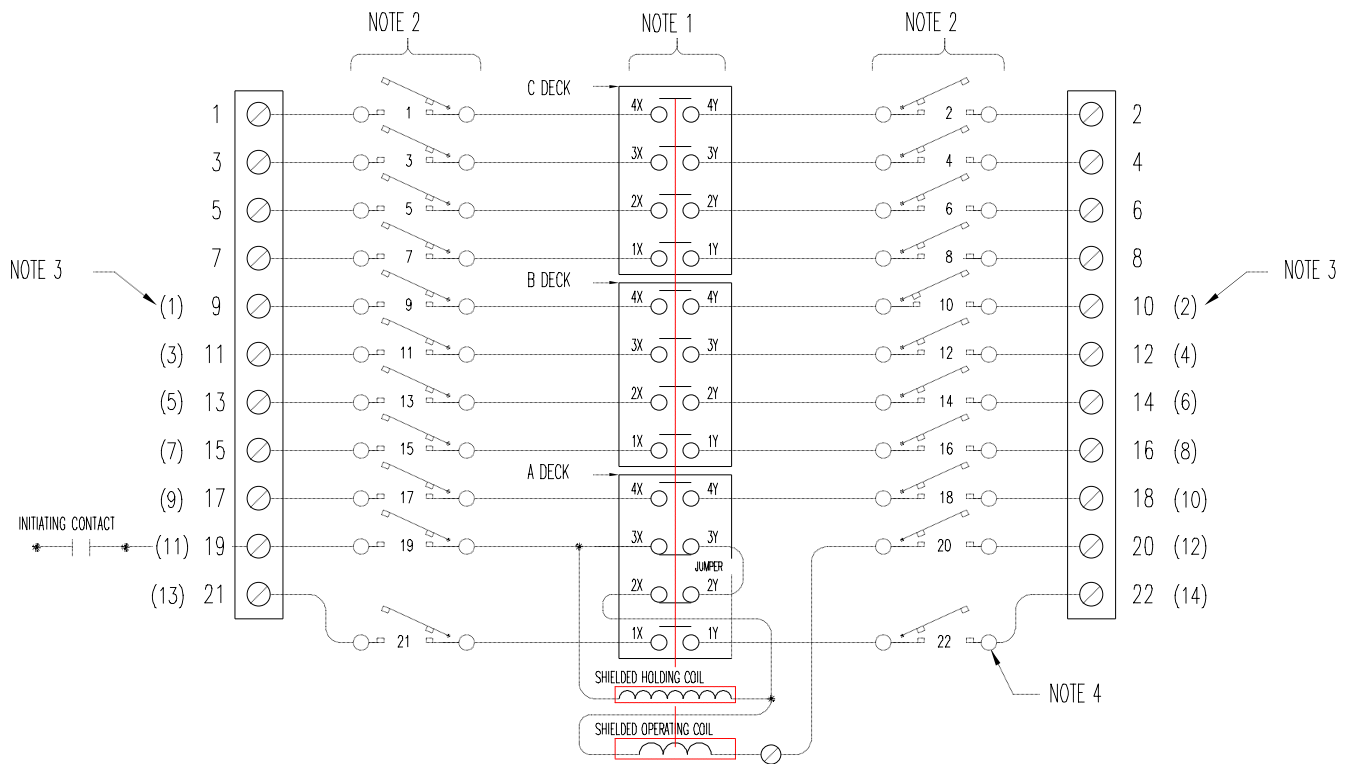

NOTES:

- 1) DOUBLE BREAK RELAY CONTACTS. UP TO (10) USABLE, CONVERTABLE CONTACTS (NORMALLY OPEN SHOWN). ADDITIONAL (2) N.C. CONTACTS DEDICATED TO HOLDING COIL. C DECK NOT PRESENT ON (6) CONTACT UNITS (SEE NOTE 3).
- 2) DOUBLE BREAK KNIFE-BLADE TEST SWITCHES AVAILABLE AS OPTION.
- 3) ON (6) CONTACT VERSION, TERMINAL BLOCK NUMBERING STARTS AT 1 ON B DECK.
- 4) BANANA PLUG JACK RECEPTACLES (3/64") - TEST POINT CONNECTIONS.

FIGURE 5. STANDARD WIRING DIAGRAM (EXCLUDING LJ4X SERIES)

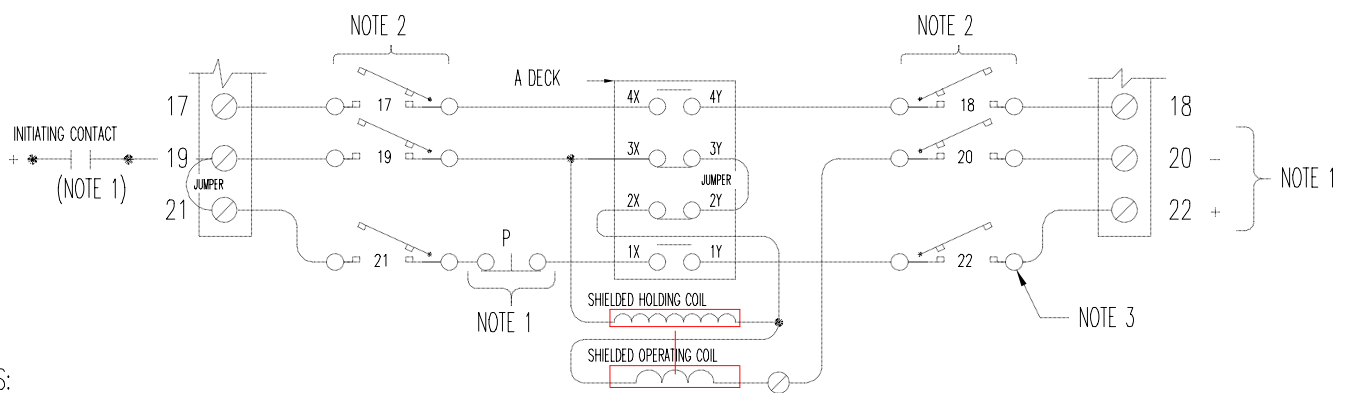

NOTES:

- 1) ELECTRICAL SEAL-IN OPTION INCLUDES MANUAL RESET PUSHBUTTON (P) AND EXTERNAL TERMINAL BLOCK JUMPER AS SHOWN. RECOMMENDED INITIATING CONTACT & POWER CONNECTIONS ALSO SHOWN.
- 2) DOUBLE BREAK KNIFE-BLADE TEST SWITCHES AVAILABLE AS OPTION.
- 3) BANANA PLUG JACK RECEPTACLES (3/64") - TEST POINT CONNECTIONS.

FIGURE 6. ELECTRICAL SEAL IN WIRING SCHEMATIC

Panel Cutout and Drilling for Semi-Flush Cases

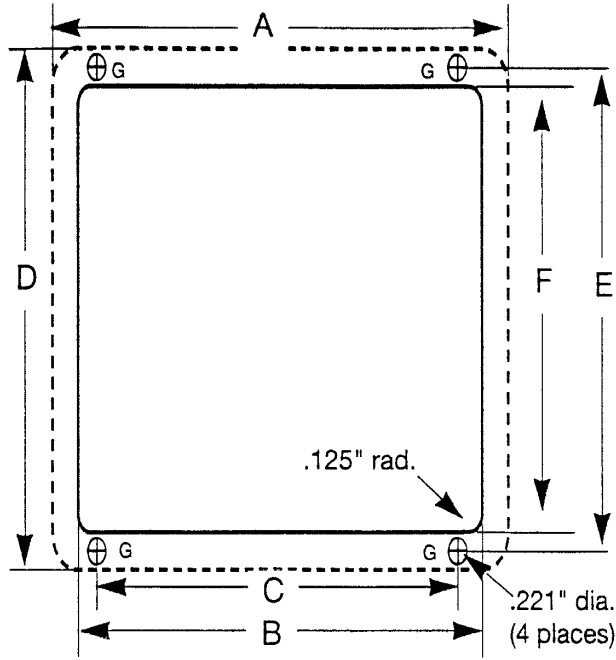

	LJ12	LJ22	LJ13	LJ23
A	3.000	5.750	3.000	6.074
B	2.625	5.500	2.625	5.572
C	2.000	5.250	2.000	5.126
D	5.000	5.675	7.000	8.000
E	4.436	5.175	6.500	7.500
F	3.875	4.812	5.875	7.056
Depth	7.000	5.976	8.250	7.400

Table 4. Cutout Dimensions (Inches)

FIGURE 7. PANEL CUTOUT

Projection Unit Mounting Footprints

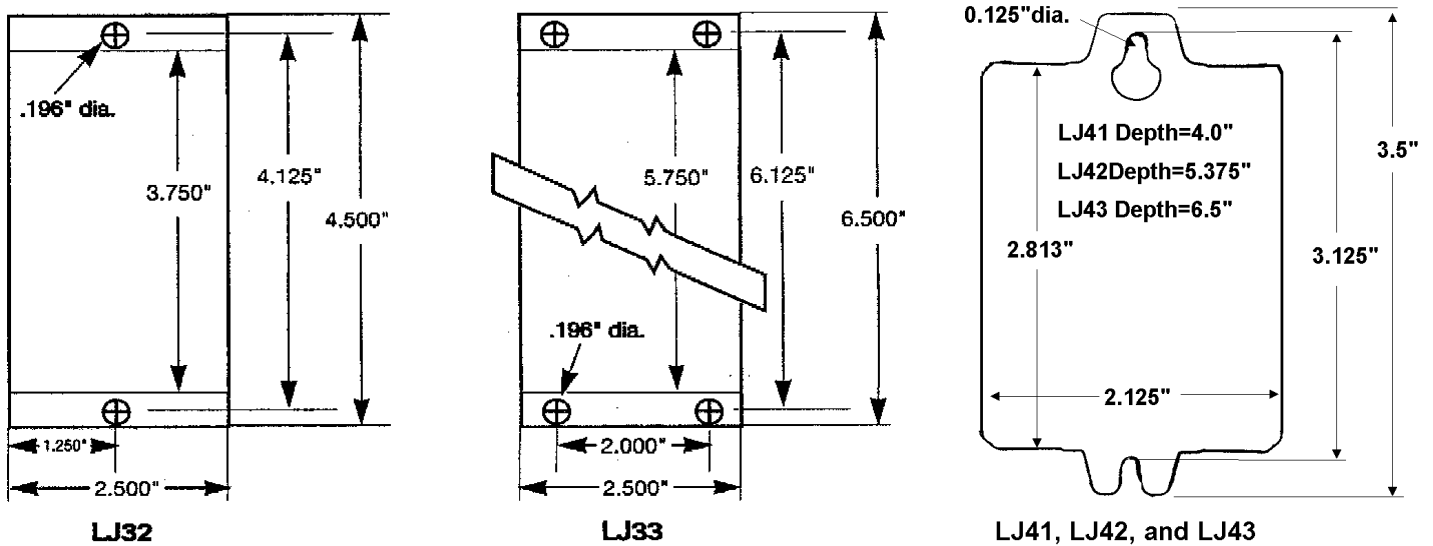

FIGURE 8. PROJECTION MOUNT DRILLING DIMENSIONS

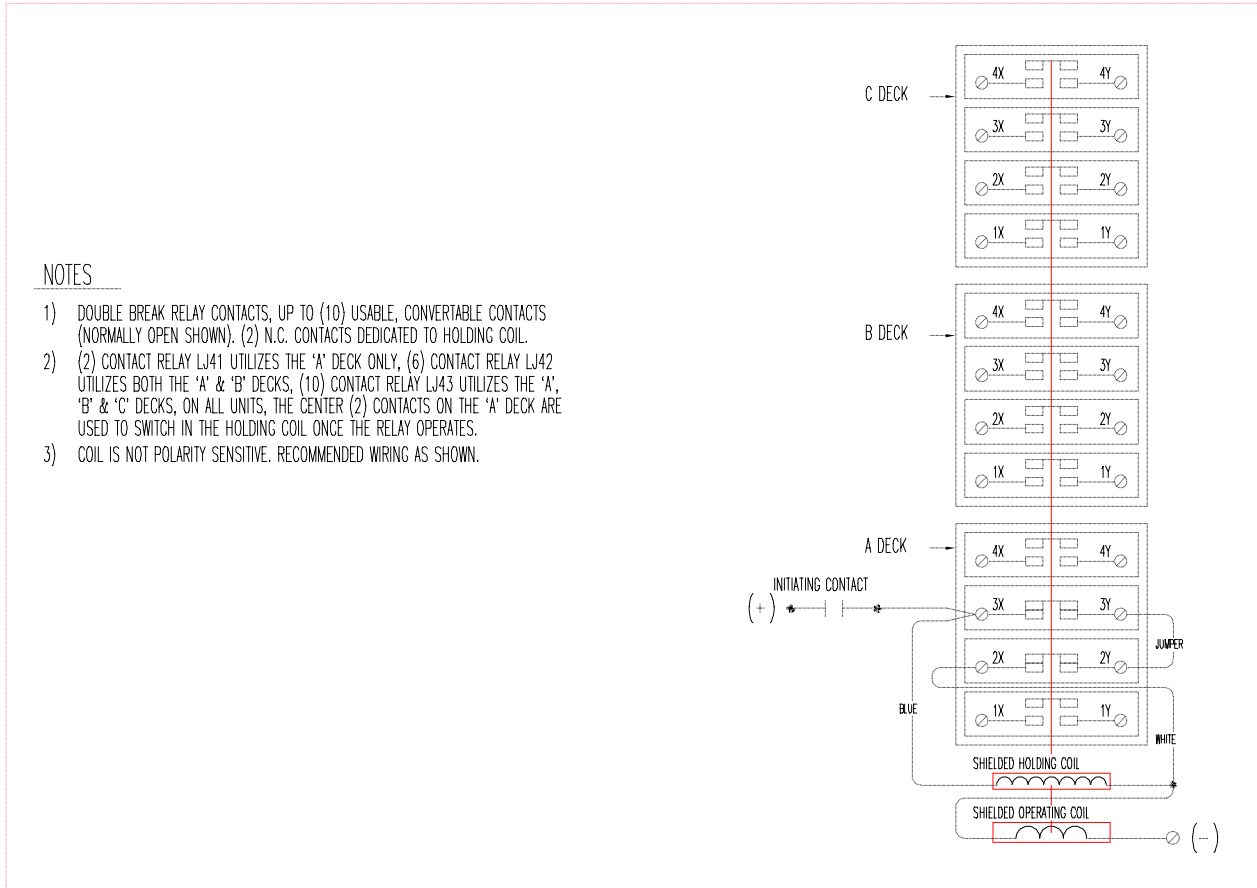
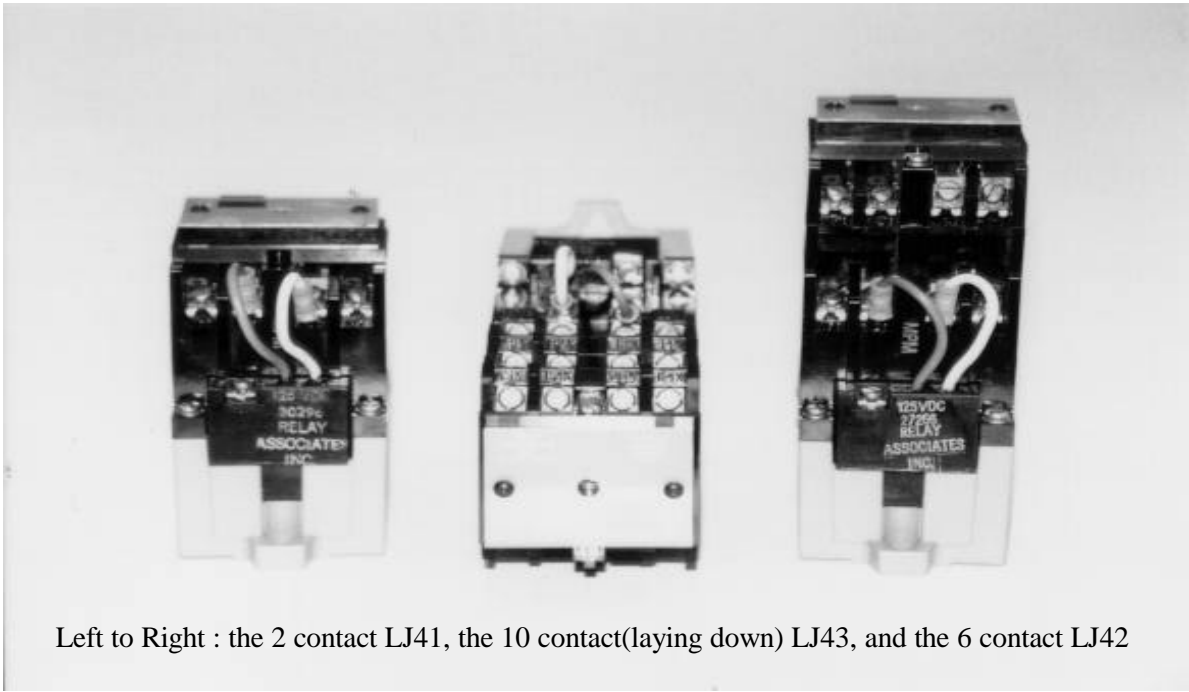

FIGURE 9. SCHEMATIC OF LJ41, LJ42, AND LJ43